THE EAST AFRICAN COMMUNITY
STATUTORY INSTRUMENTS SUPPLEMENT

No. 1

17th August, 2018.

to the East African Community Gazette No. 11 of 17th August, 2018.

Printed by the Uganda Printing and Publishing Corporation, Entebbe by Order of the East African Community.

THE EAST AFRICAN COMMUNITY
VEHICLE LOAD CONTROL (VEHICLE DIMENSIONS
AND AXLE CONFIGURATIONS) REGULATIONS, 2018.

ARRANGEMENT OF REGULATIONS

PART I—PRELIMINARY

Regulation

1. Citation.
2. Interpretation.

PART II—VEHICLE DIMENSIONS.

3. Vehicle dimensions.

PART III—AXLE CONFIGURATIONS

4. Prescribed axle configurations.
5. Wheels and tyres.
6. Liquid loads.
7. Lifiable axles.

FIRST SCHEDULE—Vehicle Dimensions and Axle Configurations

SECOND SCHEDULE—Liquid Cargo Transports

**THE EAST AFRICAN COMMUNITY
VEHICLE LOAD CONTROL (VEHICLE DIMENSIONS
AND AXLE CONFIGURATIONS) REGULATIONS, 2018.**

IN EXERCISE of the powers conferred upon the Council by sections 5 and 23 of the East African Community Vehicle Load Control Act, 2016, the Council of Ministers makes the following Regulations

PART I —PRELIMINARY.

1. These Regulations may be cited as the East African Community Vehicle Load (Vehicle Dimensions and Axle Configurations) Regulations, 2018. Inter-pretation.

2. In these Regulations, unless the context otherwise requires— Citation.

“Act” means the East African Community Vehicle Load Control Act 2016;

“authorised officer” means any person appointed as such under section 14 of the Act;

“axle” in relation to a vehicle, means a device or set of devices, whether continuous across the width of the vehicle or not, about which the wheels of the vehicle rotate and which is so placed that, when the vehicle is travelling straight ahead, the vertical centre lines of such wheels would be in one vertical plane at right angles to the longitudinal centre-line of such vehicle;

“axle group” in relation to a vehicle, means any number of axles which for the purposes of transferring load to the road pavement act in unison or together;

“axle load” means the sum of the wheel weight loads of all wheels on any axle;

“axle unit” in relation to a vehicle, means a set of two or more parallel axles of such vehicle which are so interconnected as to form a unit;

“Community” means the East African Community established by Article 2 of the Treaty;

“Council” means the Council of Ministers of the East African Community established by Article 9 of the Treaty;

“dead man’s switch” means a switch that is spring loaded and has to be held “in” by the driver while the axle is in the lifted position and as soon as the driver takes his or her hand off the switch, the axle returns to the pavement and takes up normal loading;

“Gazette” means the official gazette of the Community;

“legal load limit” means the weight that may be borne by a single axle, an axle group, or all the axles of a vehicle as specified in the Second and Third Schedules to the Act; and

“liftable axles” means a non-powered axle in an axle unit, which can be lifted independently, but which, by virtue of an automatic mechanism, must be lowered to the road pavement when the adjacent axle in the axle unit is loaded to the legal limit.

PART II —VEHICLE DIMENSIONS.

Vehicle
dimensions.

3. (1) A vehicle operated on the Regional Trunk Road Network shall conform to the vehicle dimensions provided for under the First Schedule.

(2) In determining the dimensions of a vehicle for the purposes of this regulation—

- (a) an outside rear-view mirror is not included in determining the width of the vehicle, unless the mirror protrudes more than twenty centimetres beyond the widest part of the vehicle or its load; and
- (b) a non-load bearing device used—
 - (i) to secure any load on a vehicle;
 - (ii) to contain any load on a vehicle; or
 - (iii) to cover any load on a vehicle,is not included in determining the width of the vehicle, unless the device protrudes more than ten centimetres beyond the widest part of the vehicle or its load.

PART III—AXLE CONFIGURATIONS.

4. (1) A person shall not operate a vehicle or cause to be operated any vehicle on the Regional Trunk Road Network unless—

Prescribed
axle
configurations.

- (a) the vehicle conforms to the configurations provided for in the First Schedule;
- (b) the axle load does not exceed the limits set out in the Second Schedule to the Act;
- (c) the gross vehicle weight is distributed on axles in the manner specified in the Second Schedule to the Act; and
- (d) a vehicle with a rigid body does not have more than three axles except for a vehicle with two steering axles.

(2) Notwithstanding the provisions of sub-regulation (1) the weight on an axle unit shall not exceed the manufacturer's gross axle weight rating if the manufacturer's gross axle weight is less than the amount otherwise permitted by the Act.

Wheels and
tyres.

5. (1) A person shall not drive a vehicle on any road unless it is fitted with wheels and adequately inflated pneumatic tyres, or other type of wheel or tyre adequate to carry safely the permitted maximum laden weight of the vehicle.

(2) A person shall not drive a vehicle if any wheel or tyre fitted to the vehicle is in such a condition that it does not bear a load evenly on the road surface when the vehicle is moving.

Liquid
loads.

6. (1) The volumetric capacity of a tank, constructed for the purpose of transporting liquid loads in bulk, shall not exceed the maximum volume provided in Part A of the Second Schedule.

(2) The maximum volumes of specific liquid products permitted to be loaded into each category of tank shall be as specified in Part B of the Second Schedule.

(3) A person shall not transport on the Regional Trunk Road Network quantities of bulk liquid exceeding those specified under Part B of the Second Schedule.

(4) A tank mounted on a vehicle for the purposes of transporting bulk liquids shall have affixed to each side—

(a) a diagram of the type of vehicle as specified in the First Schedule and the volume of the tank expressed in cubic metres; and

(b) a table below the diagram specified under subparagraph (a) indicating the maximum volume of bulk liquid permitted of each type of liquid product capable of being transported in the tank as specified in the Part B of the Second Schedule;

(5) The diagram and table under regulation 6 (4) shall consist of black characters on a white background, and shall be located on each side of the tank midway between the top and the base of the tank at the point nearest to the end of the tank which is closest to the front of the vehicle or trailer.

7. (1) A vehicle or trailer that is operated on the Regional Trunk Road Network may have liftable axles provided it meets the following conditions—

- (a) the liftable axles shall be authorised by the vehicle manufacturer and fitted by an accredited service provider;
- (b) the vehicle shall be fitted with a manufacturer certified dead man's switch;
- (c) the operating mechanism of the dead man's switch shall be certified by the manufacturer of the vehicle;
- (d) the liftable axle shall meet the minimum safety requirements as may be prescribed by the Council; and
- (e) the vehicle or trailer shall be registered and the liftable axles verified by the relevant authority in the Partner State.

(2) The liftable axle on any vehicle shall automatically be in the down position on the road pavement if the adjacent fixed axle is loaded to or above the legal load limit and the liftable axle can only be lifted through the operation of a dead man's switch in exceptional circumstances.

(3) In the case of a trailer or semi-trailer, the liftable axle shall be automatically in the 'down' position if the adjacent fixed axle or axle unit is loaded to or above the legal load limit.

(4) The weight limits applicable to liftable axles shall be the same as for the fixed axles as provided under regulation 4.

(5) Both wheel hubs of the liftable axle shall be painted in bright orange or red colour, to contrast with the other wheel hubs of the vehicle.

(6) A vehicle fitted with liftable axles shall have an identification plate issued by the relevant authority in a Partner State affixed on it close to the liftable axle and clearly visible.

FIRST SCHEDULE

Reg. 3 and 4

VEHICLE DIMENSIONS AND AXLE CONFIGURATIONS

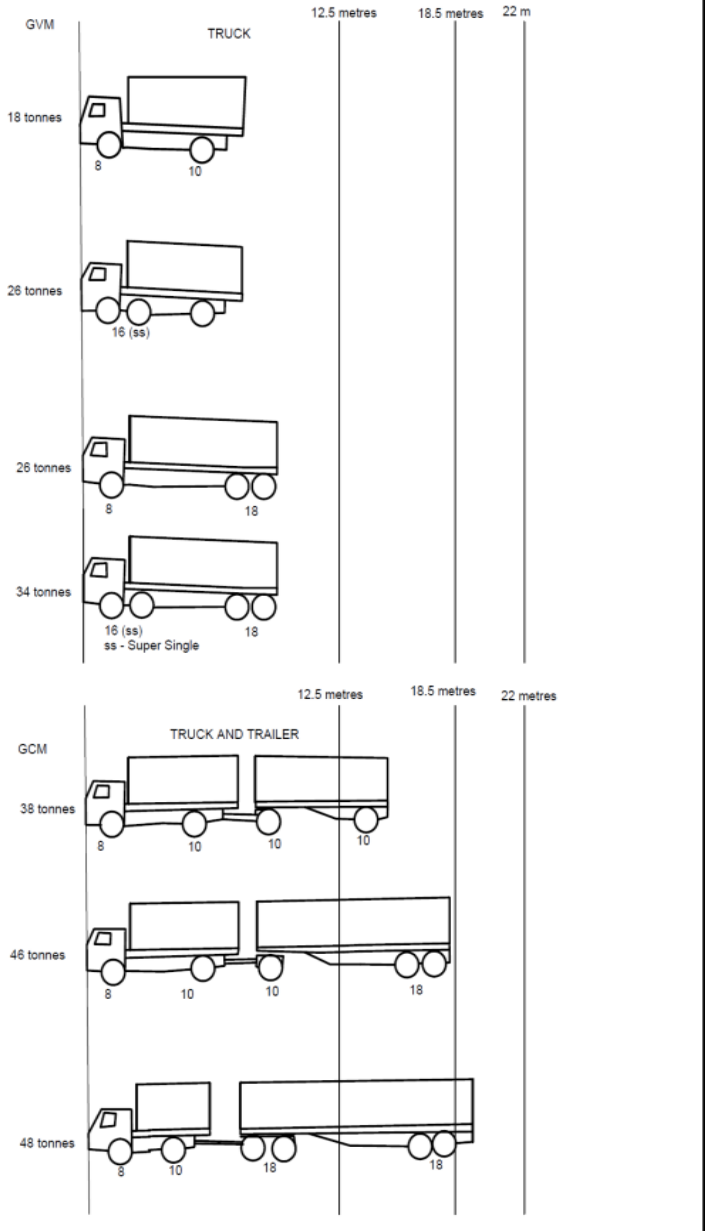

The East African Community Vehicle Load (Vehicle Dimensions and Axle Configurations) Regulations, 2018

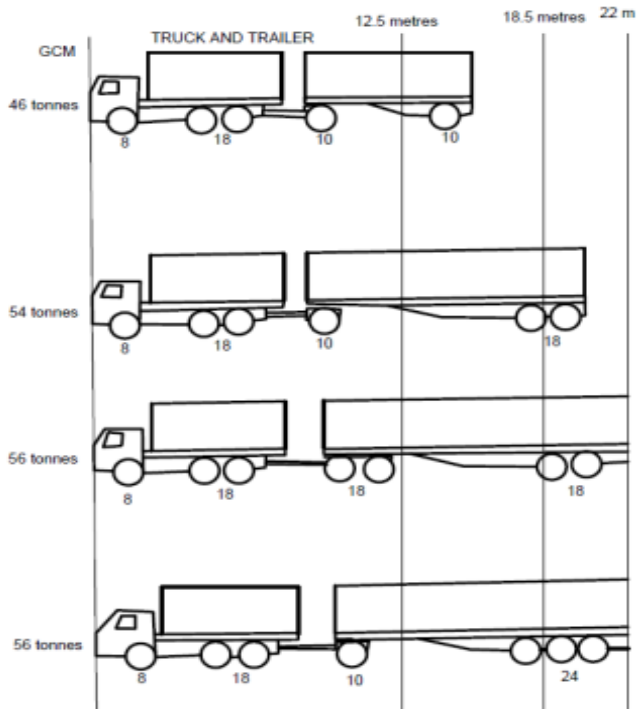
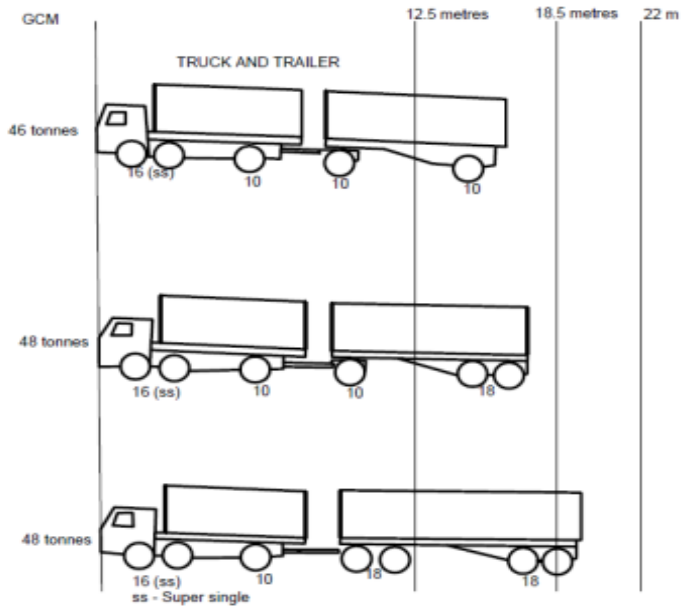

The East African Community Vehicle Load (Vehicle Dimensions and Axle Configurations) Regulations, 2018

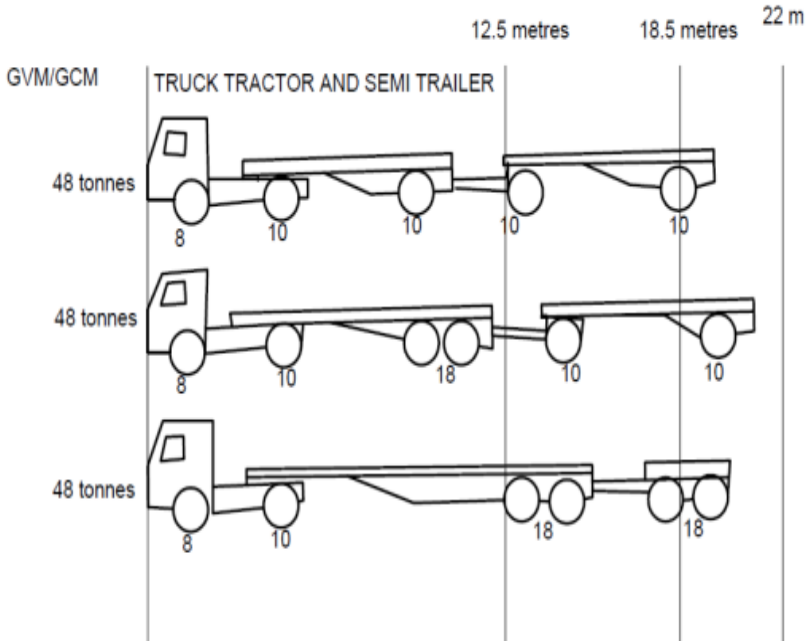
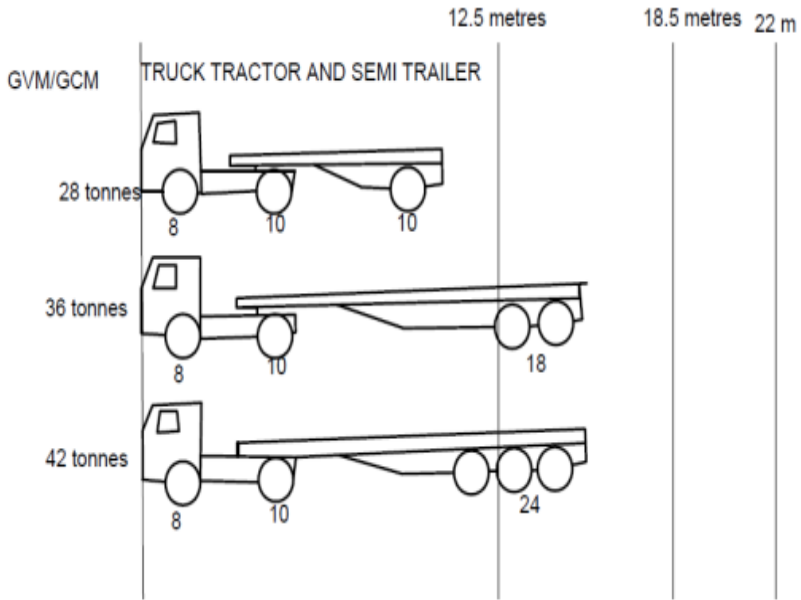

The East African Community Vehicle Load (Vehicle Dimensions and Axle Configurations) Regulations, 2018

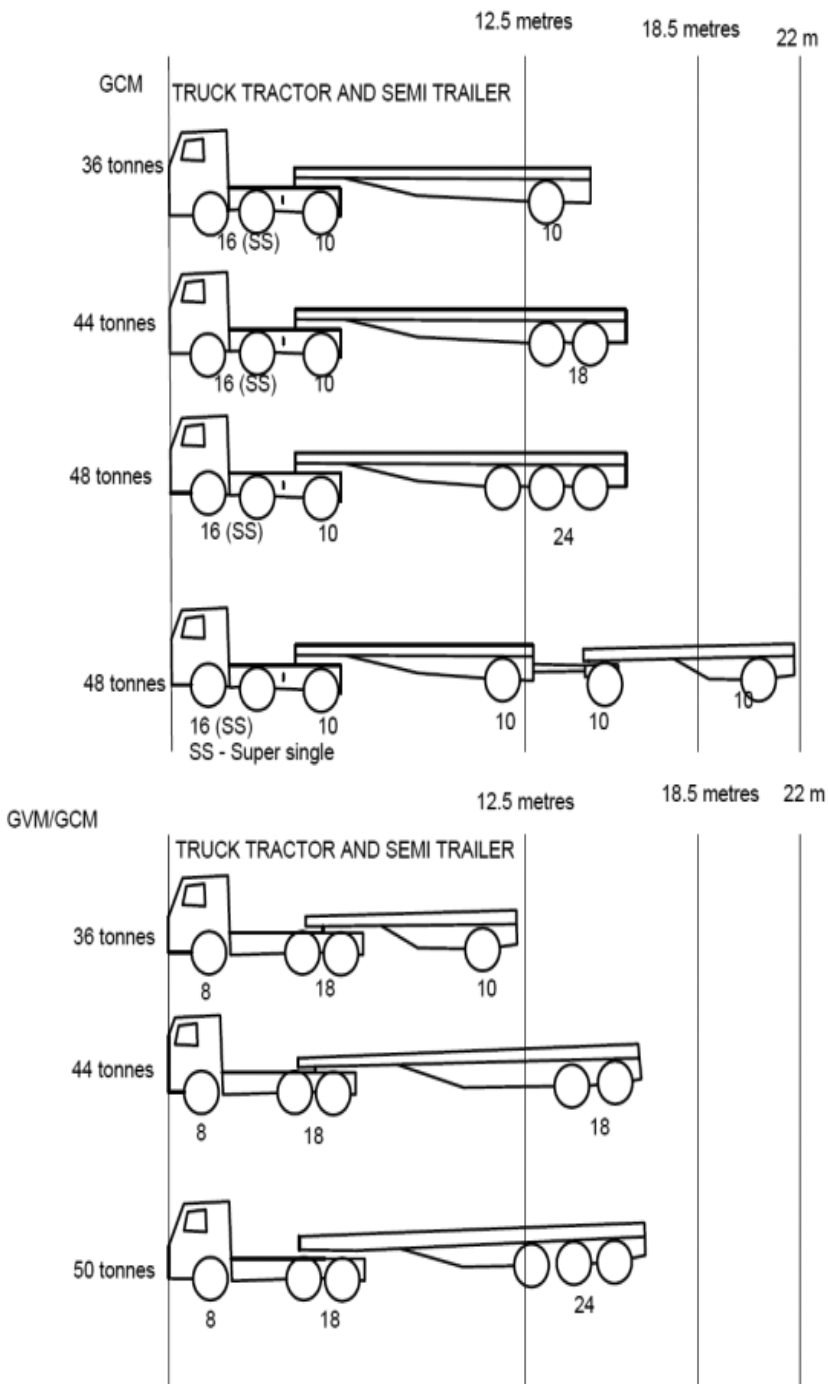

The East African Community Vehicle Load (Vehicle Dimensions and Axle Configurations) Regulations, 2018

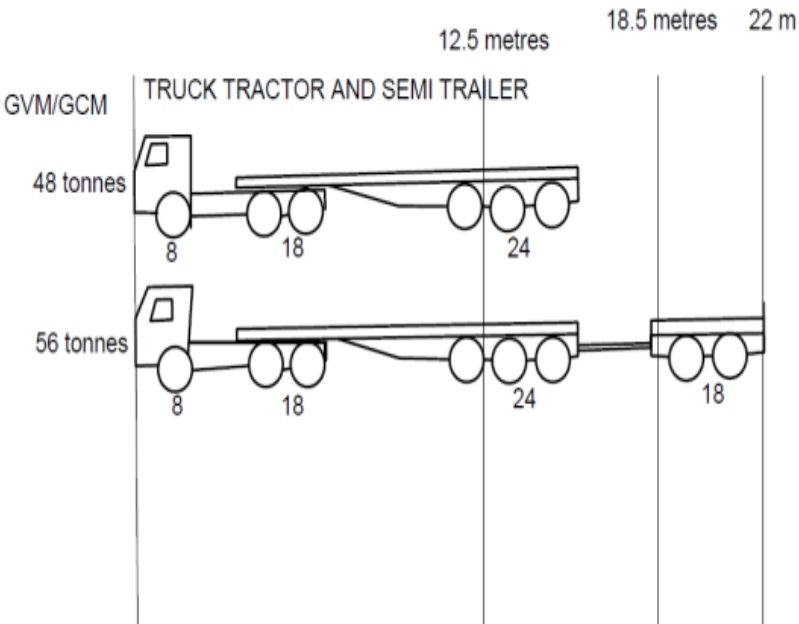
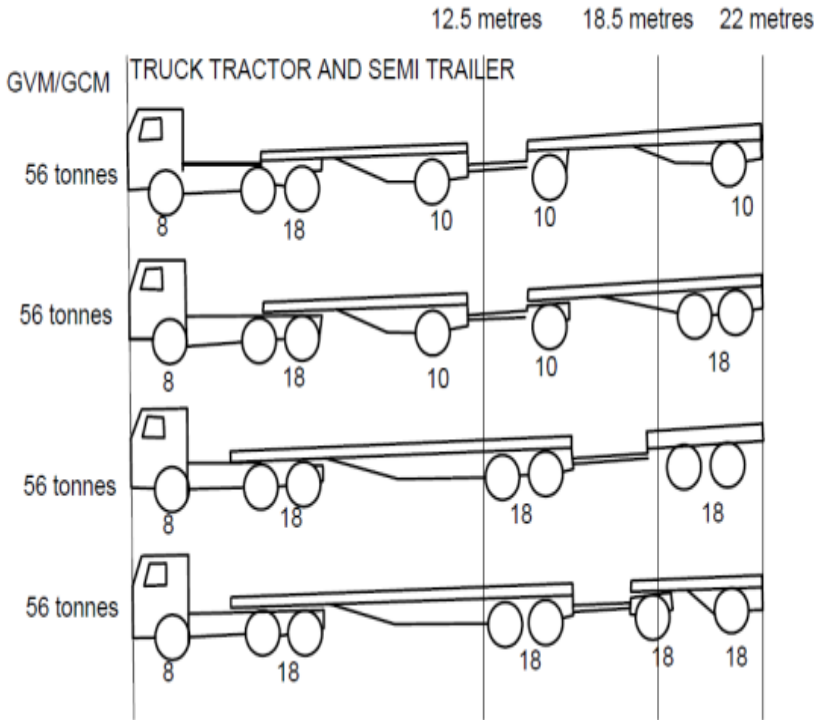

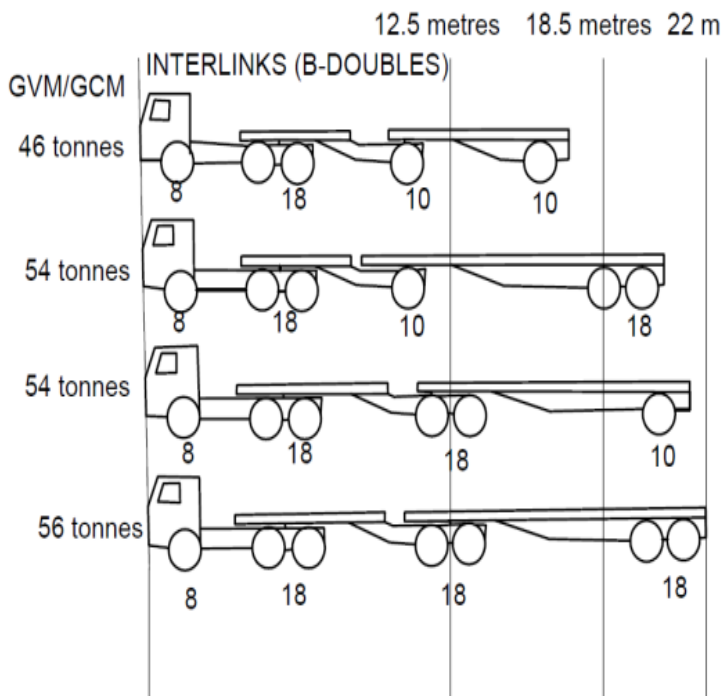
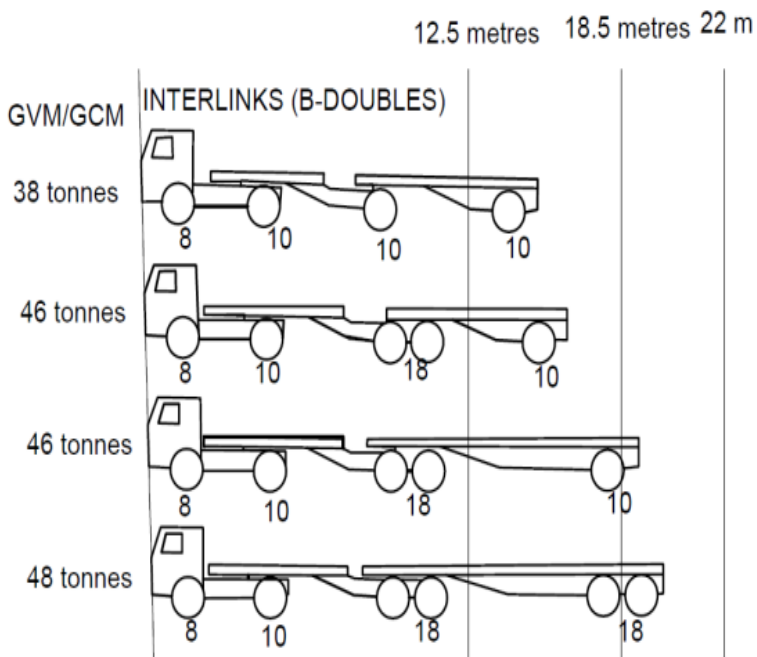

SECOND SCHEDULE

Reg. 6

PART A

STANDARDS AND SPECIFICATIONS FOR TRANSPORT OF LIQUID CARGO

Type of Vehicle or Trailer	Maximum Allowable Volume Bulk Liquid per Tank
1. Two-axle goods vehicles not exceeding 7,000 kg. tare weight	11 cubic metres
2. Three-axle goods vehicles not exceeding 7,000 kg. tare weight	18 cubic metres
3. Three-axle goods vehicles whose tare weight exceeds 7,000 kg. but does not exceed 10,000 kg	14 cubic metres
4. Two-axle draw bar trailer not exceeding 6,000 kg. tare weight	12 cubic metres
5. Three-axle draw bar trailer not exceeding 8,000 kg. tare weight	17 cubic metres
6. Three-axle semi-trailer drawn by a three-axle prime mover not exceeding 18,000 kg. total tare weight	35 cubic metres
7. Three-axle semi-trailer drawn by a two-axle prime mover not exceeding 17,000 kg. total tare weight	28 cubic metres
8. Two-axle semi-trailer drawn by a three-axle prime mover not exceeding 17,000 kg. total tare weight	24 cubic metres
9. Two-axle semi-trailer drawn by a two-axle prime mover not exceeding 15,000 kg. total tare weight	19 cubic metres

PART B

MAXIMUM ALLOWABLE VOLUME BY PRODUCT (M³)

Product	(i)	(ii)	(iii)	(iv)	(v)	(vi)	(vii)	(viii)	(ix)
Regular Petrol	11	18	14	12	17	35	28	24	19
Super Petrol	11	18	14	12	17	35	28	24	18
Kerosene	11	17	14	12	16	34	27	23	18
Aviation	11	17	14	12	16	34	27	23	18
Power Alcohol	11	17	14	12	16	34	27	23	18
Diesel	10	16	13	11	15	31	25	22	17
Industrial Diesel	9	15	12	10	14	30	24	21	16

Where—

- (i) Stands for truck (150 mm by 200 mm)- rigid body vehicle with 2 axles
- (ii) Stands for truck (150 mm by 200 mm)- rigid body vehicle with 3 axles
- (iii) Stands for truck (150 mm by 200 mm)- rigid body vehicle with 3 axles
- (iv) Stands for truck (150 mm by 200 mm)- semi trailer with 2 axles
- (v) Stands for truck (150 mm by 200 mm)- semi trailer with 3 axles
- (vi) Stands for truck (150 mm by 350 mm)- vehicle with semi-trailer with 6 axles
- (vii) Stands for truck (150 mm by 350 mm)- vehicle with semi-trailer with 5 axles
- (viii) Stands for truck (150 mm by 350 mm)- vehicle with semi-trailer with 5 axles
- (ix) Stands for truck (150 mm by 350 mm)- vehicle with semi-trailer with 4 axles

RT HON. DR. A.M. KIRUNDA KIVEJINJA,
Chairperson Council of Ministers.